

Athlegen Venus - CODE - QAVC

The Athlegen Venus is suitable for a wide range of modalities, including massage and beauty treatments. The top configuration is designed so that the motorised backrest automatically tilts the seat, perfect for positioning clients in a totally relaxing reclined/seated position. The adjustable face cradle can be slightly lowered enabling the prone patient to fully relax the neck muscles giving optimum comfort - ideal for massage treatments.

The sturdy design helps to optimize your performance whilst achieving maximum comfort and support for your clients. Combine this with quiet height adjustment and you have discovered just a few reasons why this is the perfect table for your salon or spa.



Shown with optional armrests, body/shoulder supports, and extendable footrest

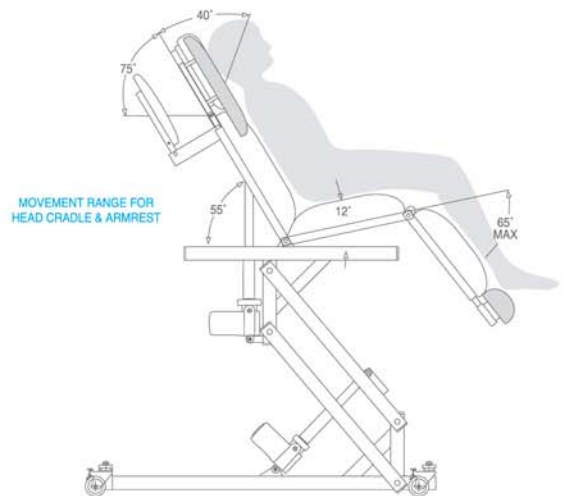
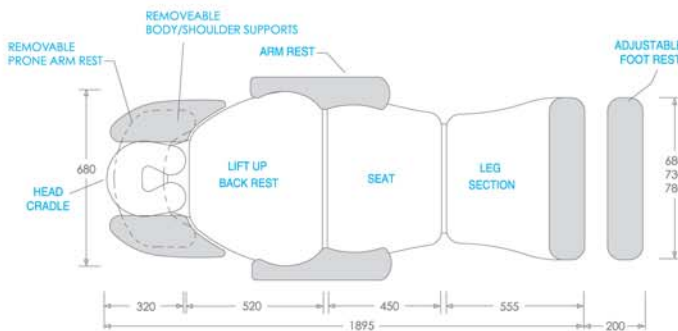

features

- Electric power height adjustment system is driven by a commercial grade linear actuator made in Germany, ensuring fast, reliable and vibration free performance.
- Power driven back rest and auto tilting seat section can be adjusted effortlessly as required during the treatment.
- 8 pivot lifting arm mechanism, super strong, with self lubricating nylon bushes to ensure smooth and quiet operation.
- Upholstery construction features special high density foam rubbers and incorporates soft edge technology.
- High quality protective coated vinyl with oil resistant properties; durable, with a soft and comfortable feel.
- Unique Access top design allows improved practitioner access during treatments while minimizing fatigue and discomfort.
- Heavy duty, industrial quality lockable castors with a chrome housing, steel bearings and a rubber wheel tread.
- Durable powder coated rust resistant frame.
- Heavy duty stainless steel footswitch
- Built to last with very low maintenance.

specifications

Maneuverability

360° rotation, heavy duty industrial quality lockable casters.

Covering

PVC tested to AS 1441.11, AS 1530.3, AS 4088.1

Cushioning

CFC free, polyurethane foam

Frame

Powder coated, rust resistant steel frame

Maximum working height

1020mm (with standard foam)

Minimum working height

560mm (with standard foam)

Maximum working load

175kg

Power requirements

240 VAC @ 3.4 AMPS

Table Length

Length with extendable foot rest (in retracted position) 1895mm
Length with extendable foot rest (in the fully extended position) 2135mm

Shipping dimensions

1900mm x 800mm x 800mm

Shipping weight

125kg

Warranty

Australia 5 years structural and 3 years motor. Extended warranty available. Other countries upon request.

Ph: 1300 785 786
Fax: 1300 785 788



www.sportstek.net
sales@sportstek.net